

THIS DRAWING IS UNPUBLISHED.

RELEASED FOR PUBLICATION

ALL RIGHTS RESERVED.

LOC
GP

DIST
00

REVISIONS

P	LTR	DESCRIPTION	DATE	DWN	APVD
P		REVISED PER ECO-11-004835	11MAR11	RK	HMR

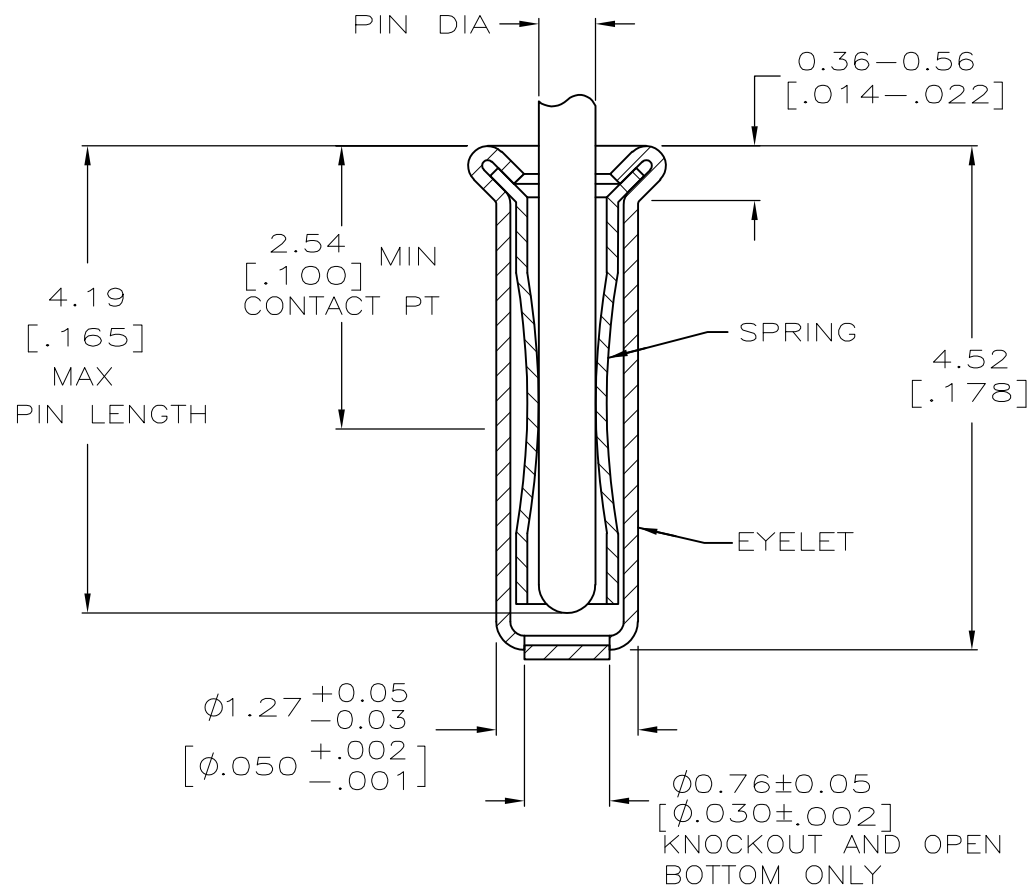
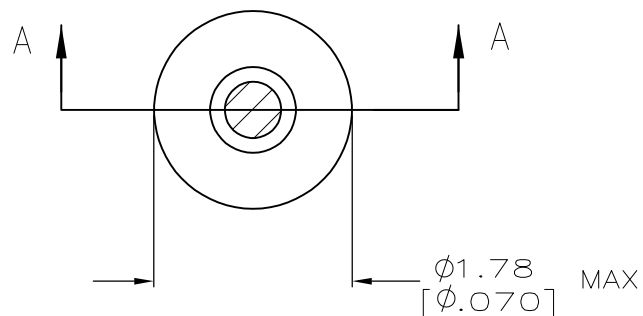

SECTION A-A

- 1. TIN PLATE PER ASTM B 545 .0.00254 [.000100] MIN THICK.
- 2. GOLD PER ASTM B 488, TYPE II, 0.00076 [.000030] MIN THK OVER NICKEL PER QQ-N-290 0.00028 [.000011] MIN THK ON CONTACT AREA.
- 3. RECOMMENDED HOLE SIZE, PLATED OR UNPLATED:
 MACHINE INSERTION: $1.32 \begin{matrix} +0.08 \\ -0.05 \end{matrix} \begin{matrix} [.052 +.003 \\ -.002] \end{matrix}$
 HAND INSERTION: $1.32 \begin{matrix} +0.10 \\ -0.00 \end{matrix} \begin{matrix} [.052 +.004 \\ -.000] \end{matrix}$
- 4. APPLICATION TOOL PART NUMBER:
 MACHINE NO. 682127-3
 INSERTION HEAD NO. 682039-2
- 5. TO INSURE PROPER SPRING TENSION DO NOT EXCEED A 0.10 [.004] DIFFERENCE IN PIN DIA WHEN CHANGING TO A SMALLER PIN.
- 6. BOTTOM PLUG KNOCKOUT TOOL PART NUMBER 69729 WITH TIP PART NUMBER 69728.
- 7. MATERIAL: SPRING: BERYLLIUM COPPER PER ASTM B 194
 EYELET: COPPER PER ASTM B 152

CLOSED	0.36-0.66 [.014-.026]	TIN 1	GOLD 2	5050462-8
OPEN			TIN 1	5050462-7
BOTTOM TYPE RECOMMENDED PIN DIA 5		EYELET	GOLD 2	5050462-2
			SPRING	PART NO
			FINISH	

THIS DRAWING IS A CONTROLLED DOCUMENT.		DWN J. ALCORTA - DOCK5 20APR2005	TE Connectivity		
DIMENSIONS: mm [INCHES]		CHK J. HAVENER 20APR2005			
TOLERANCES UNLESS OTHERWISE SPECIFIED:		APVD J. HAVENER 20APR2005	NAME MINIATURE SPRING SOCKET ASSEMBLY SERIES 2		
0 PLC ± - 1 PLC ± - 2 PLC ± - 3 PLC ± 0.20 [.008] 4 PLC ± - ANGLES ± -		PRODUCT SPEC -	DRAWING NO A3 00779 C-5050462		
MATERIAL 7		FINISH SEE TABLE	WEIGHT -	RESTRICTED TO -	
CUSTOMER DRAWING			SCALE 20:1	SHEET 1 OF 1	REV P